

INSTRUCTION MANUAL

FUNCTION GENERATOR

MODEL 459

KIKUSUI ELECTRONICS CORPORATION

Z1-402-820 IA001781

802852 1-4-64

TABLE OF CONTENTS

	<u>PAGE</u>
1. GENERAL	1
2. SPECIFICATIONS	2
3. OPERATING INSTRUCTIONS	5
3.1 Explanation of Front Panel	5
3.2 Explanation of Rear Panel	7
3.3 Notes in Use	9
4. OPERATING PRINCIPLE	11
4.1 Basic Operation	11
4.2 VCG (voltage-controlled generator)	14
4.3 Start/Stop Operation	16
4.4 DC Offset Operation	17
5. APPLICATIONS	18
5.1 Application of VCG	18
5.2 Use of DC Offset	19
5.3 Use as a Clock Generator	20

792709

1. GENERAL

Model 459 Function Generator provides an output signal of 0 ~ 20 Vp-p, 0.01 Hz ~ 1 MHz in sinusoidal wave, triangular wave or square wave. The generator is compact and light.

The oscillating frequency can be set with dials in eight decimal ranges or can be controlled with an external voltage in a VCG system for 1000-times change in one range with an external control voltage of 10 mV ~ 10 V.

Oscillation start/stop is controllable with a switch on the front panel. The output voltage is controllable with a stepwise knob for the 0, -20 and -40 dB ranges and a continuously variable knob which covers between ranges. A DC offset switch is incorporated to provide a signal superimposed on a DC component.

The function generator also provides a TTL level signal which can be used as a clock signal for digital circuits.

2. SPECIFICATIONS

Name: Function Generator

Model No.: Model 459

Oscillating frequency: 0.01 Hz ~ 1 MHz

Ranges: $\times 0.01$, $\times 0.1$, $\times 1$, $\times 10$, $\times 100$, $\times 1k$, $\times 10k$, $\times 100k$

Dial scale: Even scale, 0.1 ~ 1 ~ 10

Accuracy: (at dial scale 1~ 10)

$\times 0.01 \sim \times 1k$ ranges $\pm(2\% + 0.05$ of dial scale)

$\times 10k \sim \times 100k$ (to 500 kHz) ranges ... $\pm(3\% + 0.05$ of dial scale)

Frequency stability: $\pm 0.5\%$ or better (for $\pm 10\%$ change of line voltage)

Output waveform: Sinusoidal wave (\sim), triangular wave (\wedge)
or square wave (\square)

Maximum open output voltage: 20 Vp-p or over

Output resistance: $600 \Omega \pm 20\%$

Output voltage control: Stepwise attenuator for 0, -20, -40 dB;
continuously-variable adjustment

Frequency response:

0.01 Hz ~ less than 500 kHz with reference to 1 kHz ... 0.5 dB or less

500 kHz ~ 1 MHz with reference to 1 kHz 1 dB or less

Amplitude stability: $\pm 0.5\%$ or less (for $\pm 10\%$ change of line voltage)

792711

Mutual voltage deviation: $\pm 5\%$ or less (at maximum output, 1 kHz)

Distortion factor (sinusoidal wave):

20 Hz ~ less than 100 kHz 0.8% or less

100 kHz ~ 500 kHz 1.5% or less

DC offset: Adjustable to \pm (peak value) of maximum output;
effected by pulling the OFFSET knob.

VCG

Control voltage: Approx. 10 mV ~ 10 V

Controllable frequency: 0.01 Hz ~ 1 MHz

Ranges: $\times 1 \sim \times 100k$ ranges

Variable range: 1000 times or over, within one range

Input resistance: Approx. 10 k Ω or over, single ended

Input frequency range: DC ~ 1 kHz

Sync. signal output level: TTL level, 7400 equivalent

Start/stop: Controllable with front panel switch

Ambient temperature: 5°C ~ 35°C (41°F ~ 95°F)

Power requirements: 100 V $\pm 10\%$, 50/60 Hz AC, approx. 11 VA

Dimensions: 200 (W) \times 80 (H) \times 250 (D) mm
(7.87 (W) \times 3.15 (H) \times 9.84 (D) in.)

Maximum dimensions: 220 (W) \times 90 (H) \times 295 (D) mm
(8.66 (W) \times 3.54 (H) \times 11.61 (D) in.)

86.3.20
792712A

Weight: Approx. 2.7 kg

Accessory: Instruction manual 1 copy

3. OPERATING INSTRUCTIONS

3.1 Explanation of Front Panel (See Figure 1.)

- ① **POWER:** When this pushbutton switch is depressed and locked, the instrument power is turned on and the power pilot lamp (LED) lights.
- ② **RANGE:** Selects the oscillating frequency range. The dial reading multiplied by the selected range value is the oscillating frequency.
- When in DIAL mode: 0.01 Hz ~ 100k (all ranges)
When in VCG mode: 1 Hz ~ 100k (green letters)
- ③ **FREQUENCY:** Continuously variable adjustment of the oscillating frequency. The frequency increases as this dial is turned clockwise.
- ④ **VCG:** Selects between VCG mode and DIAL mode. The depressed and locked state is for VCG.
- ⑤ **START** Start/stop control of frequency oscillation. When depressed and locked, the oscillation starts and continues.

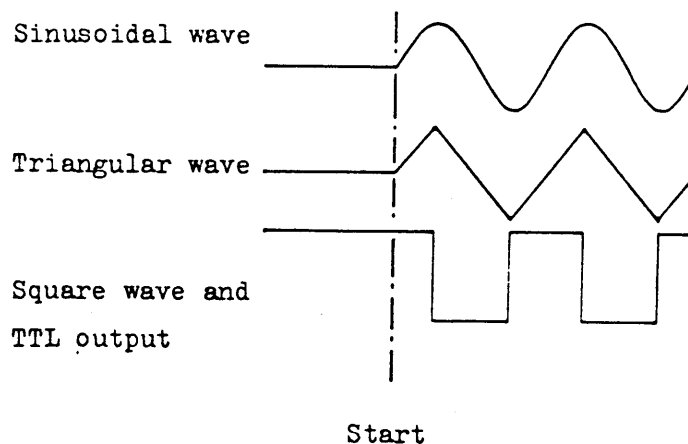

- ⑥ DC OFFSET: For superposing a DC component on the oscillated AC component. The DC component is provided when this switch is pulled out and it is continuously variably adjustable up to the maximum peak value of output voltage. If the sum of DC component and AC component exceeds ± 10 V, the signal is saturated. Operate within ± 10 V.
- ⑦ FUNCTION: Selects the output signal waveform among sinusoidal (\sim), triangular (\wedge), and square (\square).
- ⑧ OUTPUT: Continuously variable adjustment of output voltage -- the output voltage increases as this knob is turned clockwise. When DC OFFSET is effected, the waveform amplitude is adjustable with this knob.

- ⑨ ATTEN: Attenuator for stepwise attenuation
(0, -20, -40 dB) of output voltage.
- ⑩ OUTPUT TERMINAL: Provides the output signal of 0 ~ 20 V_{p-p},
with output resistance 600 Ω. BNC terminal
with the ground line isolated from the
casing although connected to the front panel.
- ⑪ TTL OUTPUT: Provides TTL level output signal synchronized
with the oscillating frequency. The output
is with 7400-equivalent logic IC.
- ⑫ VCG INPUT
TERMINAL: Input terminal for VCG mode, to control the
oscillating frequency with an input voltage
10 mV ~ 10 V.

3.2 Explanation of Rear Panel (See Figure 3-2.)

- ⑬ FUSE: Fuse in the AC power line. 0.5 A
- ⑭ POWER CORD: To be connected to an AC power line outlet of
100 V, 50/60 Hz.

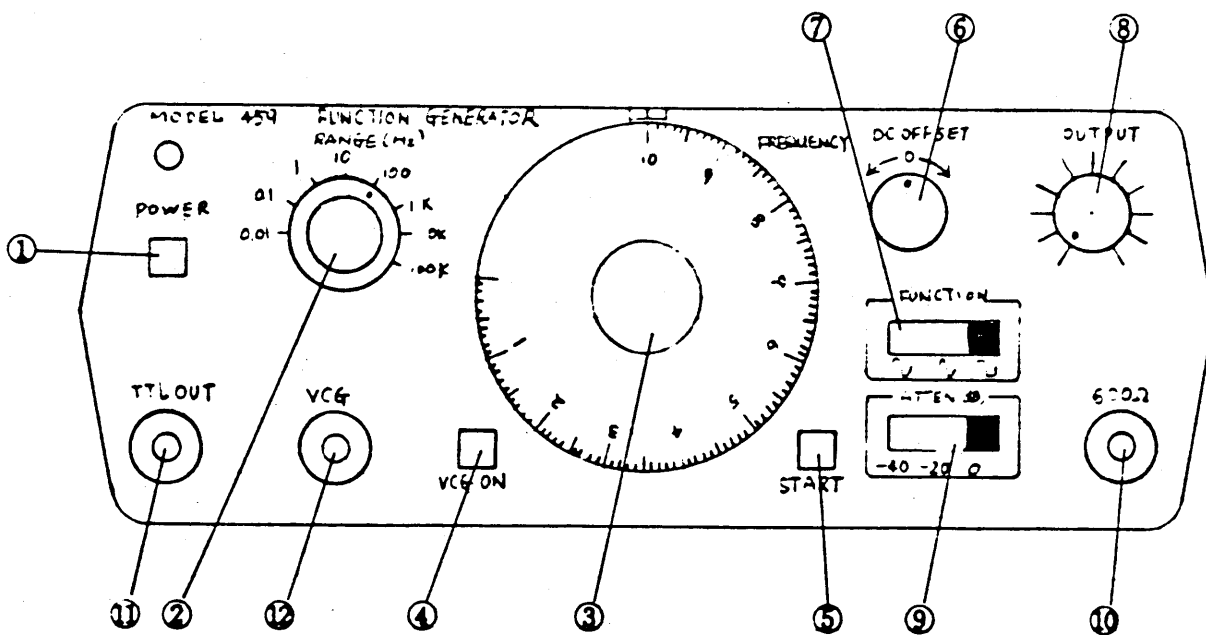

Figure 3-1

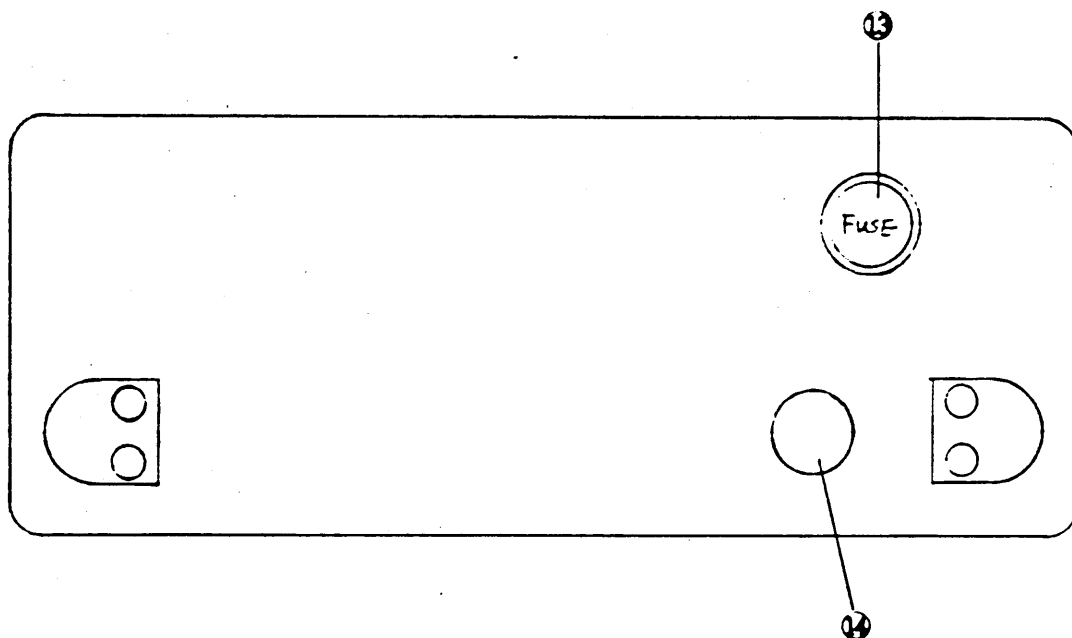
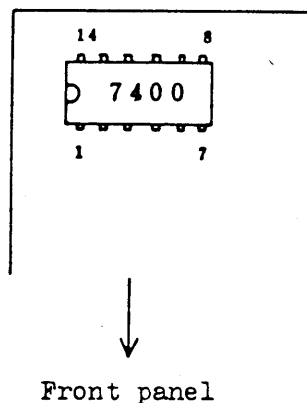

Figure 3-2

3.3 Notes in Use

- (1) Do not use the instrument under direct sunlight or other heat source, lest instrument temperature should become abnormally high.
- (2) The power requirements are 100 V $\pm 10\%$, 50/60 Hz AC. Note that the instrument may not operate properly or may be damaged in an abnormal voltage is applied.
- (3) The signal ground line is floated from the case, although it is connected to the front panel.
- (4) The dial plate rotates very lightly. Do not rotate it with an unreasonably large force lest its stopper should be broken.
- (5) The TTL output is directly led from the 7400 IC in order to provide a high waveform quality. When the IC has become defective, replace it observing the pins of the IC and its socket.

Layout of 7400 IC



- (6) When using the output voltage at a low level, a stable operation can theoretically be obtained by attenuating the signal with the attenuator and finely adjusting with the continuously-variable knob.
- (7) The instrument oscillates up to 1 MHz. At a high frequency, however, as the output resistance of the main output is 600 Ω , the signal may be affected by the capacitance of the load connected to the output.

4. OPERATING PRINCIPLE

4.1 Basic Operation

A basic block diagram of the Function Generator is shown in Figure 4-1. The instrument is composed of a flip-flop, integrator, voltage comparator, and sinusoidal wave synthesizer.

Assume that, at the instant the power is turned on, the charge of the integrating capacitor C is zero and the potential of point "a" of the flip-flop is $-E V$ as initial conditions. The potential of output point "b" of the integrator consisting of integrating capacitor and inverting amplifier rises in the positive direction. When the potential has risen to the reference value $+ E_r V$, the voltage comparator operates, a trigger signal is generated, the flip-flop is inverted, and the potential of point "a" becomes $+ E V$.

Consequently, the potential of integrator output point "b" starts falling. When the potential has reached the reference value $- E_r V$, the voltage comparator operates, a trigger signal is generated, and the flip-flop returns to the initial state. The above actions are repeated to maintain oscillation. The oscillating frequency is determined by the voltage of point "a", integrating resistance, integrating capacitance, and reference voltage of voltage comparator.

In general, integrating resistance R_2 and capacitance C are used to determine the range and the voltage of point "a" is varies with R_1 for continuously-variable frequency adjustment.

The reference voltage $\pm E_r$ of the voltage comparator is fixed.

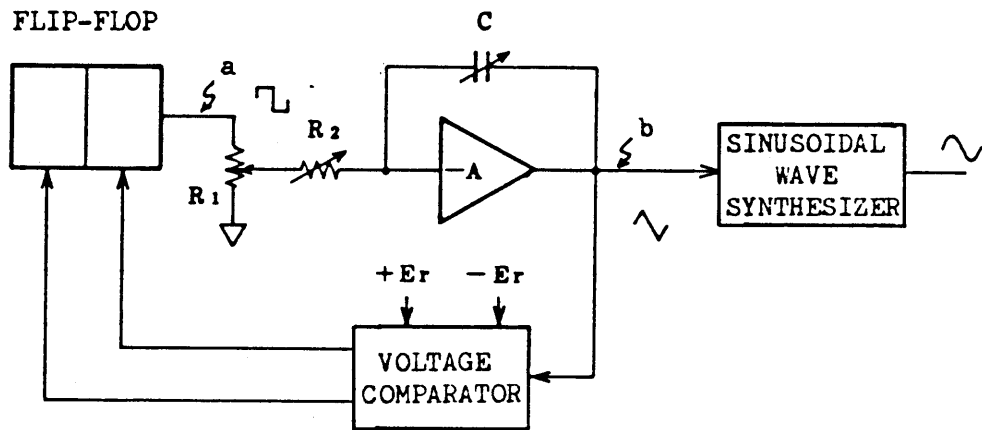

Figure 4-1

A sinusoidal wave is obtained by applying to a broken-line approximation circuit the triangular wave generated by the oscillator circuit.

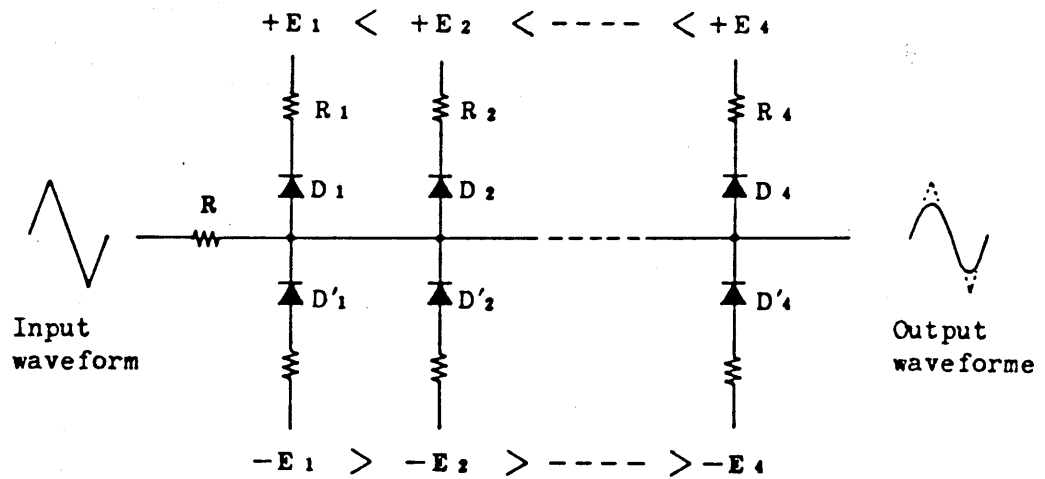

Figure 4-2

The operating principle of the broken-line approximation circuit is shown in figure 4-2. Diodes $D_1 \sim D_4$ to $D'_1 \sim D'_4$ are connected with series resistors which are weighted so that the approximation values of the broken-lines become optimal.

When instantaneous value "e" of the triangular input is $0 < "e" < +E_1$, all diodes are OFF. The gradient of the input waveform is unaltered and the input signal is directly fed to the output circuit.

When the input signal has become $+E_1 < "e" < +E_2$, diode D_1 is turned ON and the gradient of the output is reduced to $R_1/(R_1 + R)$. Further, as diodes $D_2 \dots D_4$ are turned ON, the gradient becomes still more gentle.

For a negative voltage also, diode $D_1' \sim D_4'$ are sequentially turned ON for gradient conversion.

Thus, the triangular wave is converted into a sinusoidal wave in a broken-line approximation method.

4.2 VCG (voltage-controlled generator)

A generator or oscillator the oscillating frequency of which is controlled with a voltage is called VCG or VCO. The oscillating frequency of a VCG is controlled by producing a +/- integration voltage which is proportional to the input voltage or producing a +/- integration current. For this instrument, the latter current method is employed from the viewpoint of attaining a large variable range.

A blockdiagram of the VCG circuit of this instrument is shown in Figure 4-3.

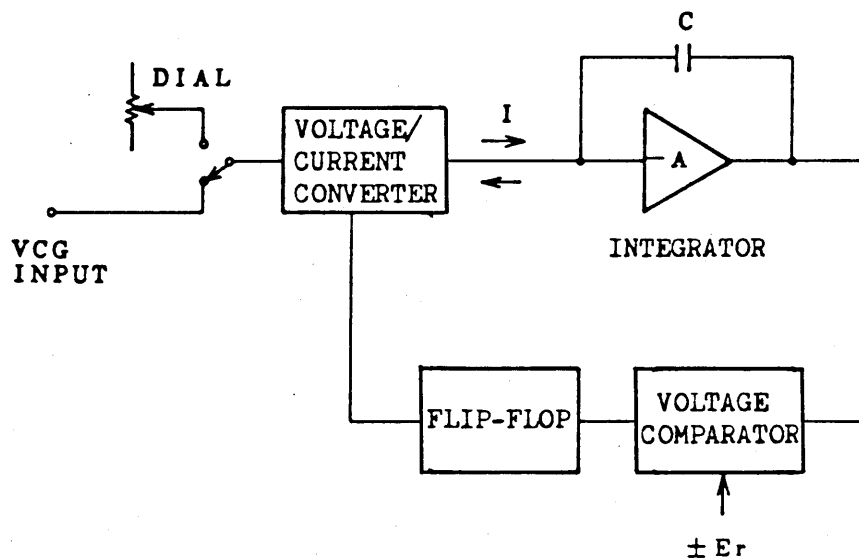

Figure 4-3

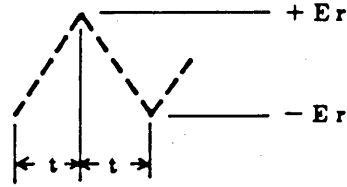

Figure 4-4

Denoting by "I" the constant current with which the integrating capacitor C is charged and discharged, by $\pm E_r$ the reference voltage of the voltage comparator, and by "t" the period from +Er to -Er as shown in Figure 4-4, equation (1) can be written.

$$2 E_r = I \cdot t/C \dots\dots\dots (1)$$

The oscillating frequency $f = 1/2t$ can be expressed as follows:

$$f = I/4 E_r C \dots\dots\dots (2)$$

As capacitance C reference voltage of equation (2) is maintained constant, the oscillating frequency is directly proportional to the current, that is, the oscillating frequency can be controlled by varying the current. The voltage-current converter produces this current for charging the capacitor "C" by converting the voltage signal into a current signal. The polarity of the current is controlled by the flip-flop.

792724

4.3 Start/Stop Operation

The start/stop control operation is done by controlling the integrator, with a circuitly as shown in Figure 4-5 where switch SW_1 is a normally-closed type (non-lock state).

Normally, the anode of diode CR_1 is grounded through switch SW_1 and is in the OFF state while diode CR_2 is in the ON state. (If the integrating current I is positive, however, diode CR_2 is ON.) There, amplifier A_1 and integrator $-A_2$ make up a closed loop through feedback resistor R_f , and they, including resistor R_i , make up an operational amplifier. The circuit does not oscillates as the integrating current I is absorbed by A_1 through CR_2 .

Consequently, the integrator output voltage E_o can be expressed as follows:

$$E_o = E_i \times R_f/R_i$$

Where, E_i : Input voltage

The integrator output can be set by setting the input voltage E_i .

Next, as you press the switch SW_1 , diode CR_1 is turned ON, diode CR_2 is inversely biased and turned OFF, the closed loop becomes open, and the current I flows into the capacitor and the oscillation starts. When in the stop state, integrating current I is the

792725

positive polarity. This state remains the same after the oscillation has started and the integration operation starts on the positive current.

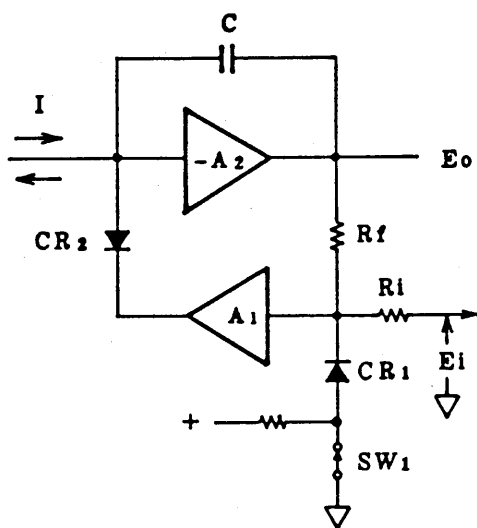
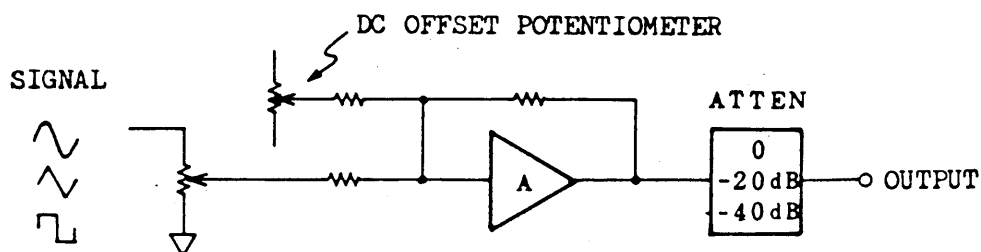

Figure 4-5

4.4 DC Offset Operation

The DC offset operation is accomplished by adding a DC voltage to the AC signal at the output amplifier.



5. APPLICATIONS

5.1 Application of VCG

5.1.1 V-F Converter

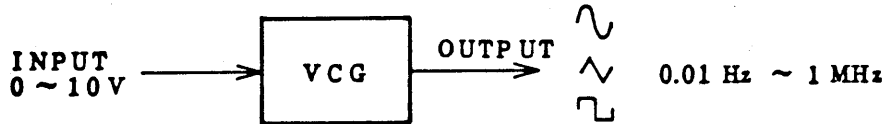

By setting the instrument in the VCG mode and applying an input voltage of 10 mV ~ 10 V, frequency can be varied by 1000 times within a single range.

5.1.2 Programmable Oscillator

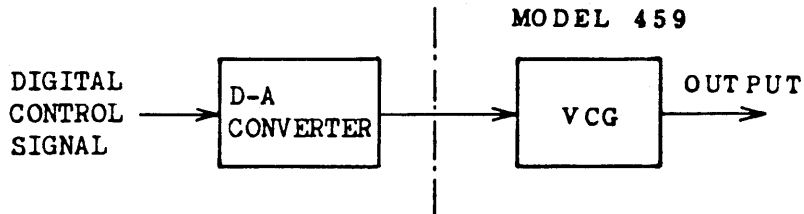

By connecting a D-A converter in the input circuit of the application of the above paragraph 5.1.1, the oscillating frequency is controllable with a digital level signal.

5.1.3 Swept Oscillation

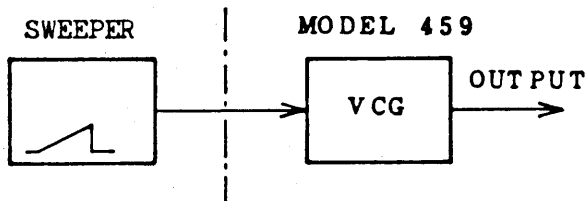

792727

By applying to the VCG input terminal a sawtooth sweep signal which varies 10 mV ~ 10 V, the oscillating frequency can be swept to up to 1000 times in one range.

OUTPUT WAVE FORM



INPUT WAVE FORM

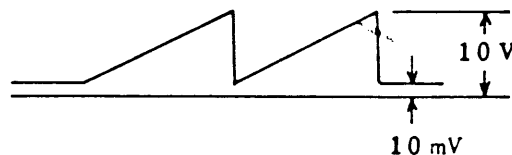

5.2 Use of DC Offset

When the DC offset feature is OFF, the output is referenced to the zero DC level, when an output in one polarity alone is required or when a DC component is required to be added to the AC signal, the DC offset feature is used. The DC offset range is ± 10 V with the attenuator set in the 0 dB state.

The DC offset knob should be adjusted taking into consideration the setting of the continuously variable AC output signal control knob, the maximum allowable voltage of the sum of DC component plus AC component is ± 10 V peak, if the voltage is higher than this, the signal is saturated.

The attenuator is effective to the sum of the two components.

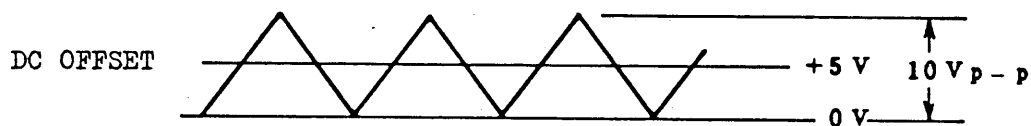

The DC offset knob becomes effective when it is pulled out and the DC component voltage increases as the knob is turned clockwise.

5.3 Use as a Clock Generator

The instrument has an independent TTL output terminal which provides the output signal of an internal 7400 equivalent IC. The output signal can be used as a clock signal for digital circuits.

CLOCK GENERATOR

